

# SPA 6 - 12 | VRLA Battery



## Applications

- Uninterruptible Power Supplies (UPS)
- Electric Power Systems (EPS)
- Emergency backup power supplies
- Electronic apparatus and equipment
- Communication power supplies
- DC power supplies
- Auto control system

## Specifications

Nominal Voltage	6 V	
Number of cells	3	
Design Life	10 years	
Dimensions	Length	151 mm
	Width	50 mm
	Height	94 mm
	Total Height	100 mm
Approx. Weight	1.70 kg	
Nominal Capacity (25°C)	20 hours rate (0.60 A, 5.25 V)	12.0 Ah
	10 hours rate (1.12 A, 5.25 V)	11.2 Ah
	5 hours rate (2.04 A, 5.25 V)	10.2 Ah
	1 hour rate (7.80 A, 4.80 V)	7.8 Ah
Max. Discharge Current (25°C)	180 A (5s)	
Max. Charging Current (25°C)	3.6 A	
Internal Resistance	10 mOhms	
Fully Charged battery (25°C)		
Self-Discharge (25°C)	3% of capacity declined per month (average)	
Operating Temperature Range	Discharge	-15~50°C
	Charge	-10~50°C
	Storage	-20~50°C
Short Circuit Current	500 A	
Charging Characteristics (25°C)	Boost charging voltage	2.40-2.45 Vpc
	Temperature compensation	-30 mV/°C
	Float charging voltage	2.25-2.30 Vpc
	Temperature compensation	-18 mV/°C

## Battery Construction

Component	Positive Plate	Negative Plate	Container	Cover	Safety Valve	Terminal	Separator	Electrolyte
Raw material	Lead dioxide	Lead	ABS	ABS	Rubber	Copper	Fiberglass	Sulfuric acid

## Dimensions

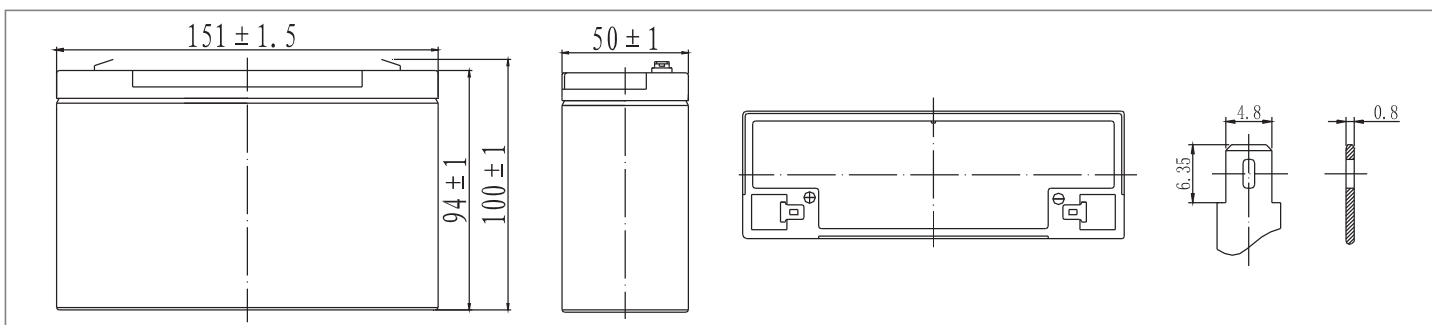

## Constant Current Discharge (Amperes) at 25°C

End Voltage (Volts/Cell)	5 min	10 min	15 min	30 min	1 h	2h	3h	4h	5h	8h	10h	20h
1.60 V	45.2	28.8	22.8	12.7	7.80	4.26	3.06	2.45	2.08	1.35	1.13	0.61
1.65 V	43.8	27.9	22.3	12.5	7.68	4.24	3.04	2.43	2.07	1.34	1.13	0.61
1.70 V	42.1	26.8	21.4	12.1	7.49	4.20	3.02	2.42	2.05	1.33	1.12	0.60
1.75 V	40.2	25.6	20.7	11.8	7.34	4.14	3.00	2.40	2.04	1.32	1.12	0.60
1.80 V	38.0	24.2	19.6	11.4	7.11	4.03	2.91	2.33	1.98	1.28	1.09	0.59

## Constant Power Discharge (Watts) at 25°C

End Voltage (Volts/Cell)	5 min	10 min	15 min	30 min	1 h	2h	3h	4h	5h	8h	10h	20h
1.60 V	253	162	130	72.9	45.2	24.9	18.2	14.6	12.4	8.08	6.80	3.65
1.65 V	247	158	127	71.4	44.5	24.8	18.1	14.5	12.3	8.03	6.77	3.64
1.70 V	236	151	122	69.2	43.4	24.6	17.9	14.4	12.3	7.98	6.74	3.62
1.75 V	227	145	118	67.6	42.5	24.2	17.8	14.3	12.2	7.92	6.70	3.60
1.80 V	213	136	112	65.1	41.2	23.6	17.3	13.9	11.8	7.68	6.56	3.53

(Note) The above characteristics data are average values obtained within three charge/discharge cycles.

# SPA 6 - 12 | VRLA Battery

## Temperature Effects on Float Life

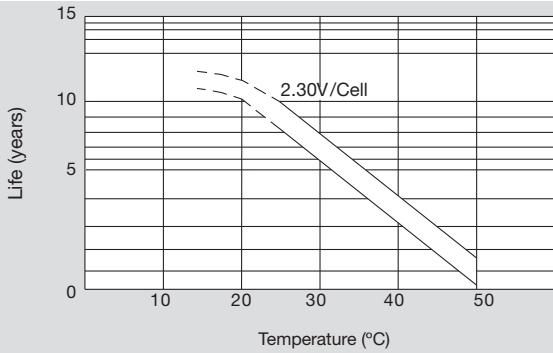

## Self Discharge Characteristics

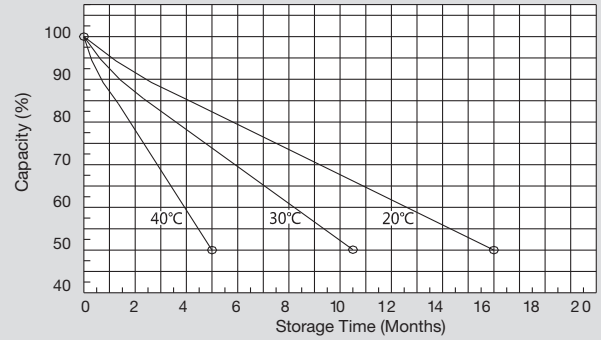

## Discharge Characteristics (25°C)

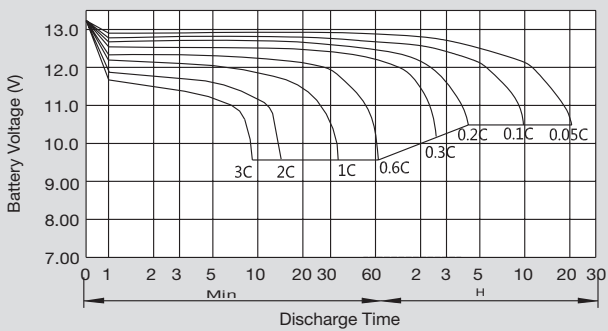

## Charging Characteristics (25°C)

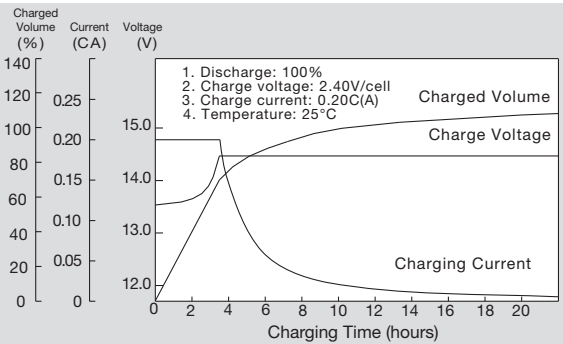

## Relationship Between Charging Voltage and Temperature

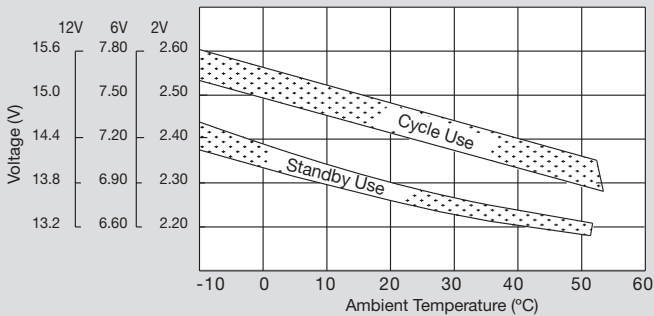

## Relationship Between Open Circuit Voltage and Residual Capacity (25°C)

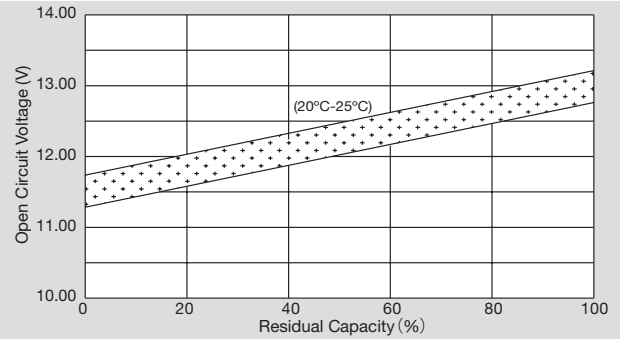

## Cycle Service Life in Relation to Depth of Discharge

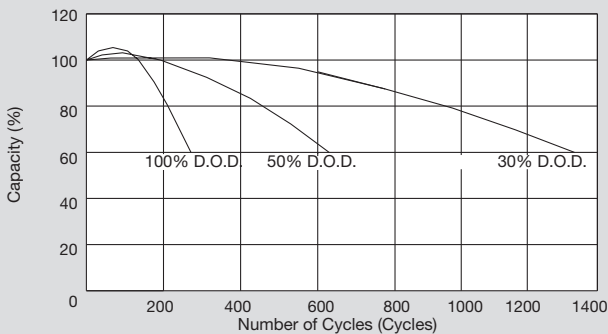

## Temperature Effects on Capacity

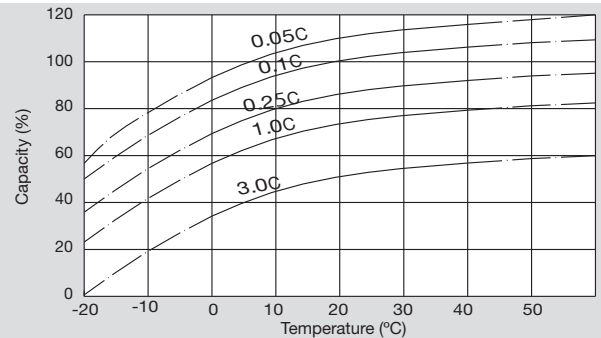

Headquarters 2 Ermou & Nikis Street | Syntagma Square | 105 63 | Athens | Greece | EU

Manufacturing Plant Neo Olvio | 672 00 Xanthi | Greece | EU

Recycling Plant Industrial Area of Komotini | 691 00 Komotini | Greece | EU

Southeast Europe Industrial Sales 14B Menexedon Street | 145 64 Kato Kifissia | Greece | EU

European Battery Assembly (SEBA) 175, Via Stra | 37030 Colognola Ai Colli Verona | Italy | EU

Industrial SRL 11, Soseaua Centurii | 077025 Bragadiru, Judet Ilfov | Romania | EU

T +30 210 6245400

T +30 25410 48100

T +30 25310 82460

T +30 210 6245600

T +39 045 7651771

T +40 021 3517777

F +30 210 6245409

F +30 25410 95446

F +30 25310 82489

F +30 210 6245619

F +39 045 7651771

F +40 021 3516667

 **SUNLIGHT**  
Reliable Battery Solutions