

□ HGL100-12A

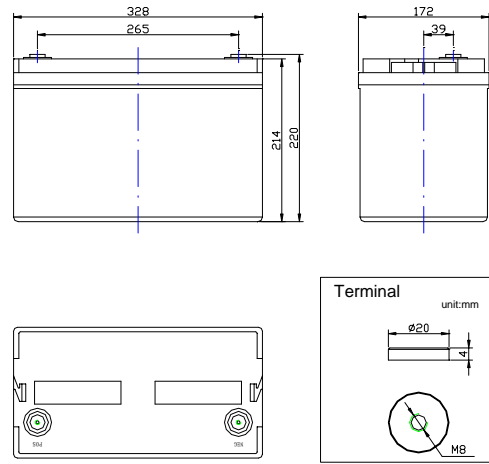

Specifications

Nominal Voltage		12V
Rated Capacity (20 hour rate)		100AH
Dimension	Total Height (with terminals)	220mm(8.66inches)
	Height	214mm(8.43inches)
	Length	328mm(12.91inches)
	Width	172mm(6.77inches)
Weight		Approx. 30.4kg (66.88lbs)

Discharge characteristics 77 °F (25°C)

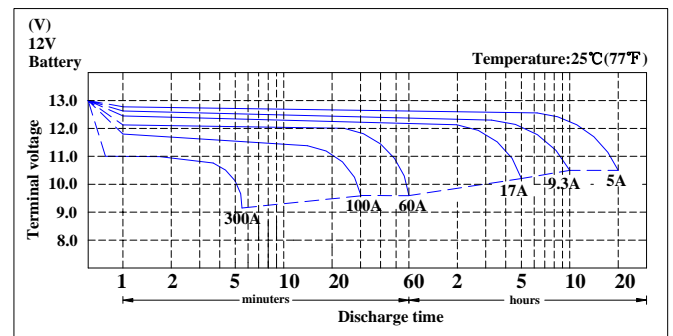

Characteristics

Capacity 77°F (25°C)	20 hour rate (5A to 10.5Volts)	100AH
	10 hour rate (9.3A to 10.5Volts)	93AH
	5 hour rate (17A to 10.2Volts)	85AH
	1 hour rate (60A to 9.6Volts)	60AH
Internal Resistance	Full charged 77°F (25°C)	3.9m Ω
Standard Terminal	M8	
Capacity affected by Temperature (20 hour rate)	104°F (40°C)	102%
	77°F (25°C)	100%
	32°F (0°C)	85%
	5°F (-15°C)	65%
Self-Discharge 77°F (25°C)	Capacity after 3 month storage	91%
	Capacity after 6 month storage	82%
	Capacity after 12 month storage	64%
Max. Discharge Current 77°F (25°C)	1000A (5s)	
Maximum Charge Current(A)	20A	
Charging (Constant Voltage)	Cycle	14.5V~14.9V/77°F (25°C)
	Float	13.6V~13.8V/77°F (25°C)
Temperature compensation coefficient of charging voltage (mV/ °C/cell)	Cycle	-4mV/°C/cell
	Float	-3mV/°C/cell

Duration of discharge vs. Discharge current

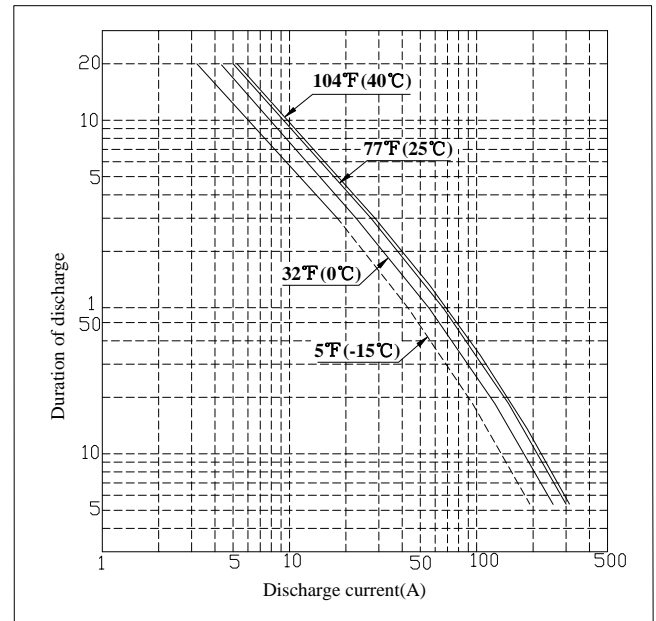

Constant Current Discharge Rating Amperes @ 77°F (25°C)

Cut off voltage V/cell	15M	30M	45M	1H	2H	3H	5H	8H	10H	12H	20H	24H
1.75V	144.5	95.1	70.9	56.4	32.2	24.5	16.6	11.37	9.3	7.98	5.0	4.19