



DEEP CYCLE
SERIES: 5000
MODEL: 2 YS 31P

BATTERY ENGINEERING
WWW.ROLLSBATTERY.COM MADE IN CANADA

BATTERY TYPE: 2 VOLTS

DIMENSIONS:

LENGTH	394 MM	15 1/2 INCHES
WIDTH	229 MM	9 INCHES
HEIGHT	803 MM	31 5/8 INCHES

WEIGHTS:

WEIGHT DRY	91 KG	200 LBS.
WEIGHT WET	129 KG	285 LBS.

CONTAINER CONSTRUCTION:

CONTAINER: (INNER)	POLYPROPYLENE	TERMINALS:	FLAG WITH STAINLESS STEEL NUTS AND BOLTS
COVER: (INNER)	POLYPROPYLENE - HEAT SEALED TO INNER CONTAINER	HANDLES:	MOLDED
CONTAINER: (OUTER)	HIGH DENSITY POLYETHYLENE		
COVER: (OUTER)	HIGH DENSITY POLYETHYLENE SNAP FIT TO OUTER CONTAINER		

PLATES:

POSITIVE PLATE DIMENSION:

HEIGHT	600 MM	23.625 INCHES
WIDTH	143 MM	5.625 INCHES
THICKNESS	6.99 MM	0.275 INCHES

NEGATIVE PLATE DIMENSION:

HEIGHT	600 MM	23.625 INCHES
WIDTH	143 MM	5.625 INCHES
THICKNESS	4.57 MM	0.180 INCHES

CELLS: 1 **PLATES/CELL:** 31

POSITIVE PLATE DOUBLE WRAPPED WITH SLYVER ENVELOPED WITH HEAVY DUTY SEPARATOR

SEPARATOR:
THICKNESS 3 MM 0.105 INCHES

INSULATION:
GLASS MAT 1 MM 0.020 INCHES

CAPACITY:

CRANK AMPS:		
COLD (CCA)	0°F / -17.8°C	5740
MARINE (MCA)	32°F / 0°C	7175

ELECTROLYTE RESERVE:
ABOVE PLATES 95 MM 3.75 INCHES

RESERVE CAPACITY:
RC @ 25A 8193 MINUTES

20 HR RATE: 2430 50% DOD

	HOUR RATE	SPECIFIC GRAVITY	CAP / AH	CURRENT / AMPS
CAPACITY @	100 HOUR RATE	1.280 SP. GR.	3426	34.26
CAPACITY @	72 HOUR RATE	1.280 SP. GR.	3232	44.89
CAPACITY @	50 HOUR RATE	1.280 SP. GR.	2989	59.78
CAPACITY @	24 HOUR RATE	1.280 SP. GR.	2527	105.3
CAPACITY @	20 HOUR RATE	1.280 SP. GR.	2430	121.5
CAPACITY @	15 HOUR RATE	1.280 SP. GR.	2260	150.7
CAPACITY @	12 HOUR RATE	1.280 SP. GR.	2114	176.2
CAPACITY @	10 HOUR RATE	1.280 SP. GR.	2017	201.7
CAPACITY @	8 HOUR RATE	1.280 SP. GR.	1895	236.9
CAPACITY @	6 HOUR RATE	1.280 SP. GR.	1725	287.6
CAPACITY @	5 HOUR RATE	1.280 SP. GR.	1628	326
CAPACITY @	4 HOUR RATE	1.280 SP. GR.	1507	377
CAPACITY @	3 HOUR RATE	1.280 SP. GR.	1361	454
CAPACITY @	2 HOUR RATE	1.280 SP. GR.	1166	583
CAPACITY @	1 HOUR RATE	1.280 SP. GR.	826	826



1 STATION RD SPRINGHILL, NOVA SCOTIA CANADA B0M 1X0 1.800.681.9914

REV.2
 Jan-10
 2YS 31P

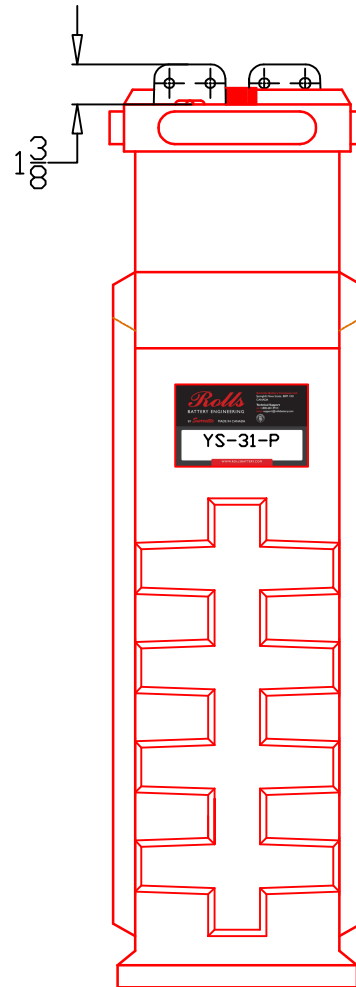
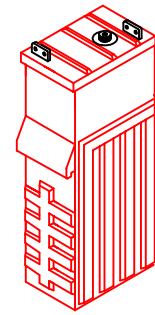
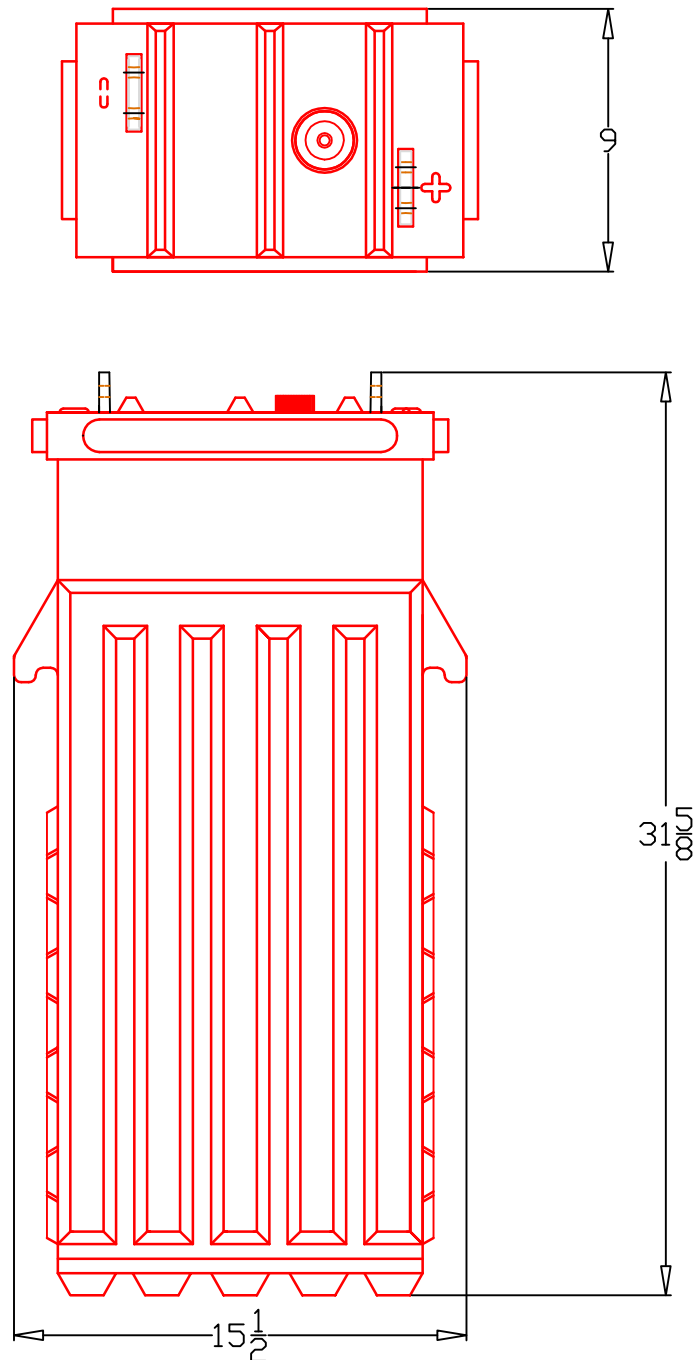

PART NUMBER: 2-YS-31P

WEIGHT WET EST: 285 LB/ 130 KG
(ESTIMATED)

WEIGHT EST: 200 LB/ 91 KG
(ESTIAMTED)

CAPACITY 2,430 AH 20 HR

VOLTAGE: 2 V

OVERALL DIMS: 15½ X 9" X 31⅝ "



MAX HT WITH OPTIONAL 32⅝"
HYDROCAPS

AVAILABLE JUL-06

Rolls
BATTERY ENGINEERING

TITLE: 2 YS 31P

DESCRIPTION:

2V / 1 CELL 31 PLATE

CONTACT INFO:

WEB: WWW.SURRETTE.COM
E-MAIL: SALES@SURRETTE.COM
PHONE: 1-800-681-9914

SCALE: 1" = 7"
8.5" X 11" JPEG:
NOT TO SCALE

DATE: JAN-2010 REVISION REV 2

DRAWING NO.: BD2YS31P