

S12-160AGM

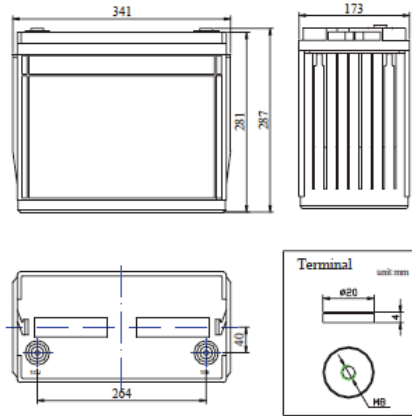

Specifications

Nominal Voltage		12V
Rated Capacity (20 hour rate)		145AH
Dimension	Total Height (with terminals)	287mm(11.30inches)
	Height	281mm(11.06inches)
	Length	341mm(13.43inches)
	Width	173mm(6.81inches)
Weight		Approx.44.3kg (97.46Ibs)

Discharge characteristics 77 °F (25 °C)

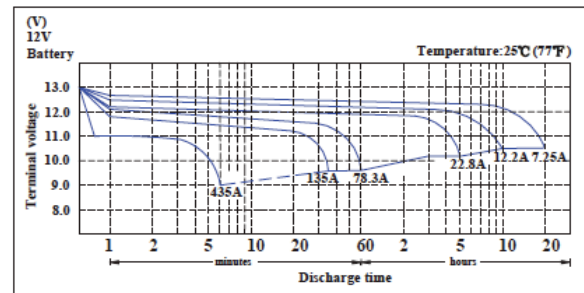

Characteristics

Capacity 77°F (25°C)	20 hour rate (7.25A to 10.5Volts)	145AH
	10 hour rate (12.2A to 10.5Volts)	122AH
	5 hour rate (22.8A to 10.2Volts)	114AH
Internal Resistance	Full charged 77°F (25°C)	3.6mΩ
Capacity affected by Temperature (20 hour rate)	104°F (40°C)	102%
	77°F (25°C)	100%
	32°F (0°C)	85%
	5°F (-15°C)	65%
Self-Discharge 77°F (25°C)	Capacity after 3 month storage	91%
	Capacity after 6 month storage	82%
	Capacity after 12 month storage	64%
Standard Terminal	M8	
Max. Discharge Current 77°F (25°C)	1400A (5s)	
Cranking Performance	Cranking Amps (30-sec amps to 7.2V @ 32° F (0° C)	975A
	Cold Cranking Amps (30-sec amps to 7.2V @ 0° F (-18° C)	820A
Reserve Capacity (Minutes to 10.5V at 80°F (27°C)	@ 25Amps	260Min
	@ 75Amps	70Min
Charging (Constant Voltage)	Cycle	Initial Charging Current 27A Or Small 14.4V~14.9V/77°F (25°C)
	Float	13.6V~13.8V/77°F (25°C)

Duration of discharge vs. Discharge current

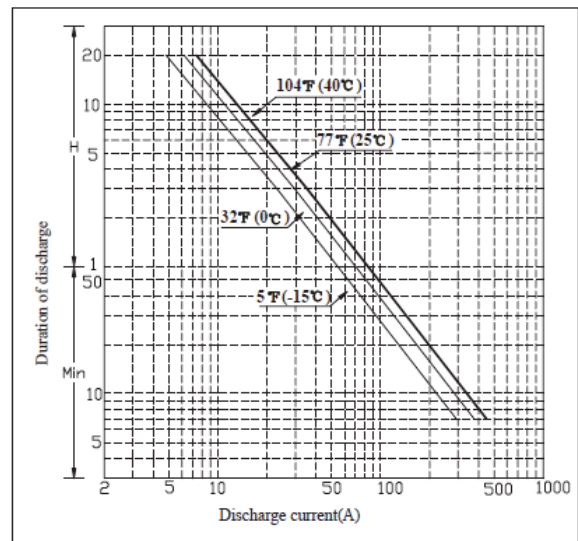

Constant Current Discharge Rating Amperes @ 77°F (25°C)

Cut off voltage V/cell	15M	30M	45M	1H	2H	3H	5H	8H	10H	12H	20H	24H
1.75V	280	134	97	76.7	43.7	31.7	21.4	14.7	12.15	10.35	7.25	6.15